

# Mountings For Rodless Cylinders

Ø18mm - Ø63mm

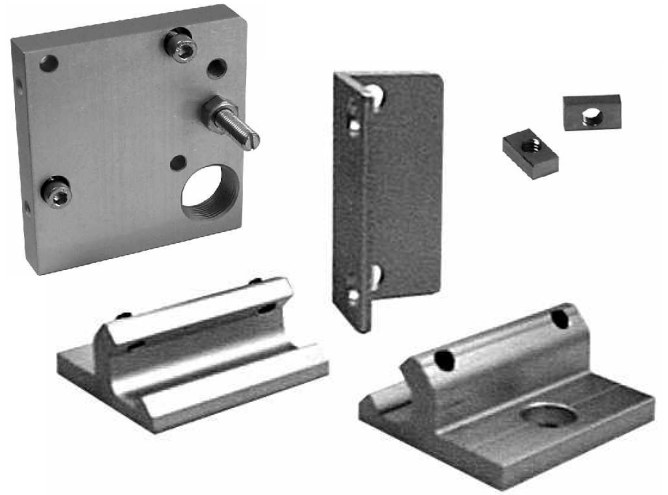

## Mountings - Foot Type

- ◆ Allows the cylinder body to be mounted at each end
- ◆ Suitable for cylinder types KCLS9 and KCLC9
- ◆ Part numbers include 2 mounting brackets and 4 fixing screws

## Dimensions

units mm

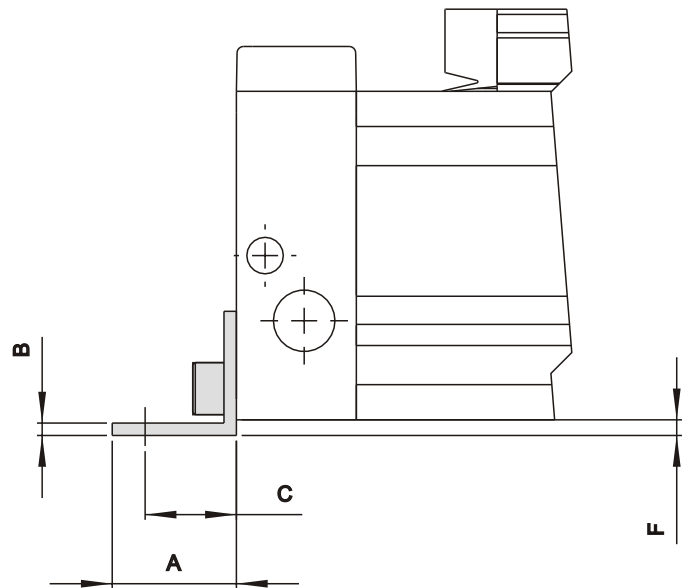
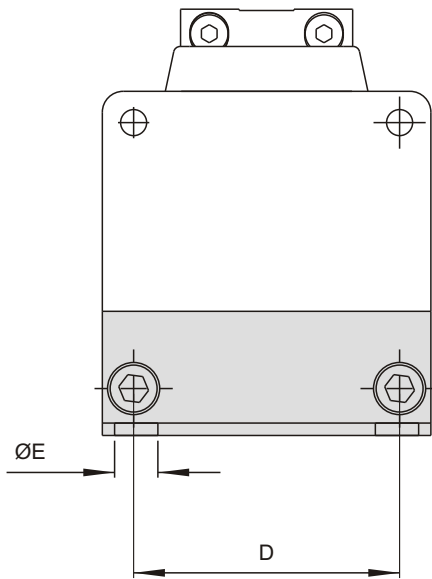

Mounting part number	Cylinder Ø (mm)	A	B	C	D	ØE	F
KCRM018K01	18	19	2.0	10.0	20	5.3	2.0
KCRM025K01	25	19	2.0	12.5	30	5.3	2.0
KCRM032K01	32	23.8	2.4	13.5	40	6.3	3.0
KCRM040K01	40	23.8	2.4	17.5	50	8.3	3.0
KCRM050K01	50	31.8	3.0	20.0	60	8.3	3.0
KCRM063K01	63	31.8	3.0	21.0	75	10.4	4.5

Ordering Information:  
By part number



® Issue 1 Oct 02

## Dimensions

units mm

### Rodless Cylinder Mountings

#### Mountings - Side Support Bracket

- ◆ These mountings provide optional supporting points along the length of the cylinder body
- ◆ Suitable for cylinder types KCLS9A/B/C, KCLC9A/B
- ◆ Part numbers include one mounting bracket and two fixing screws

For maximum distance (L) between side support brackets, refer to table

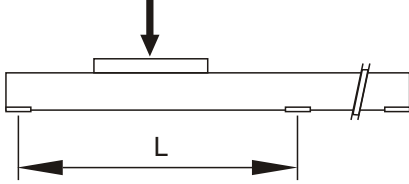

Cylinder Ø (mm)	Distance L (mm) with 0.5mm deflection						
	250N	500N	750N	1000N	1500N	2000N	2500N
18	700	-	-	-	-	-	-
25	1100	1350	700	-	-	-	-
32	1400	1100	950	850	-	-	-
40	1600	1300	1150	1050	900	-	-
50	2050	1700	1550	1350	1150	1050	-
63	2450	2050	1850	1700	1550	1350	1250

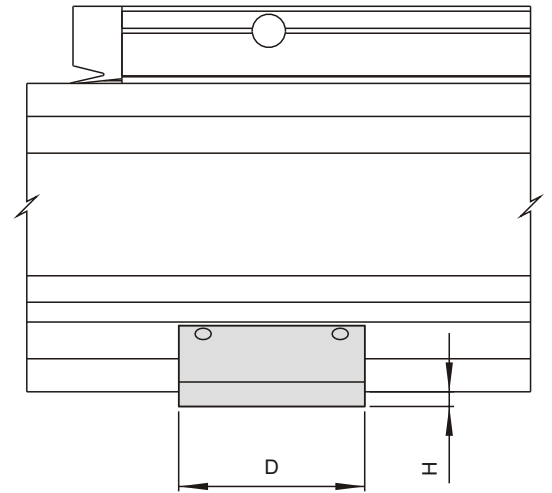
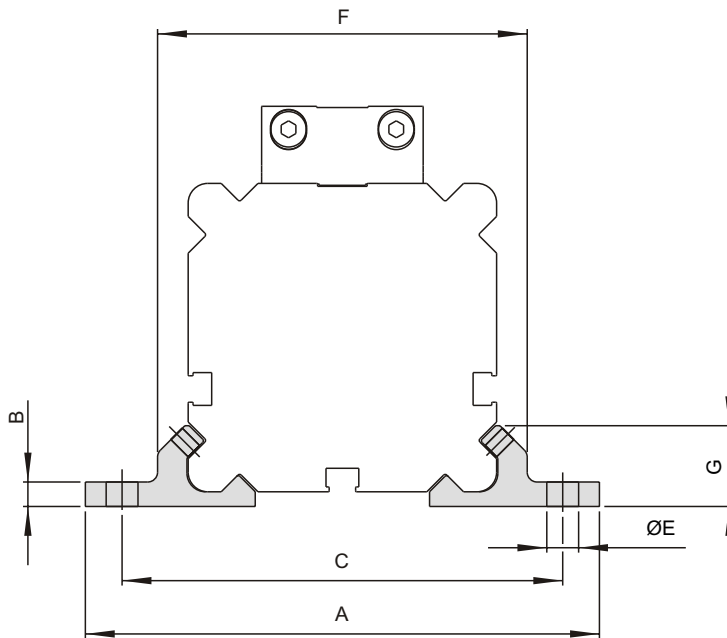

Mounting part number	Cylinder Ø (mm)	A	B	C	D	ØE	F	G	H
KCRM018K02	18	56	2.5	46	23	4.3	36.5	8.3	2.0
KCRM025K02	25	70	3.5	60	28	5.3	50.0	11.0	2.0
KCRM032K02	32	85	4.0	73	33	5.3	61.5	13.8	3.0
KCRM040K02	40	105	4.5	90	38	6.5	75.0	16.5	3.0
KCRM050K02	50	122	5.0	106	43	8.5	91.0	19.0	3.0
KCRM063K02	63	144	6.0	125	48	8.5	107	22.0	4.5

Ordering Information:  
By part number



® Issue 1 Oct 02

## Dimensions and performance data

units mm

### Mountings – Shock Absorbers

#### Features

- ◆ Allow shock absorbers to be mounted to the cylinder
- ◆ Part numbers do not include shock absorbers

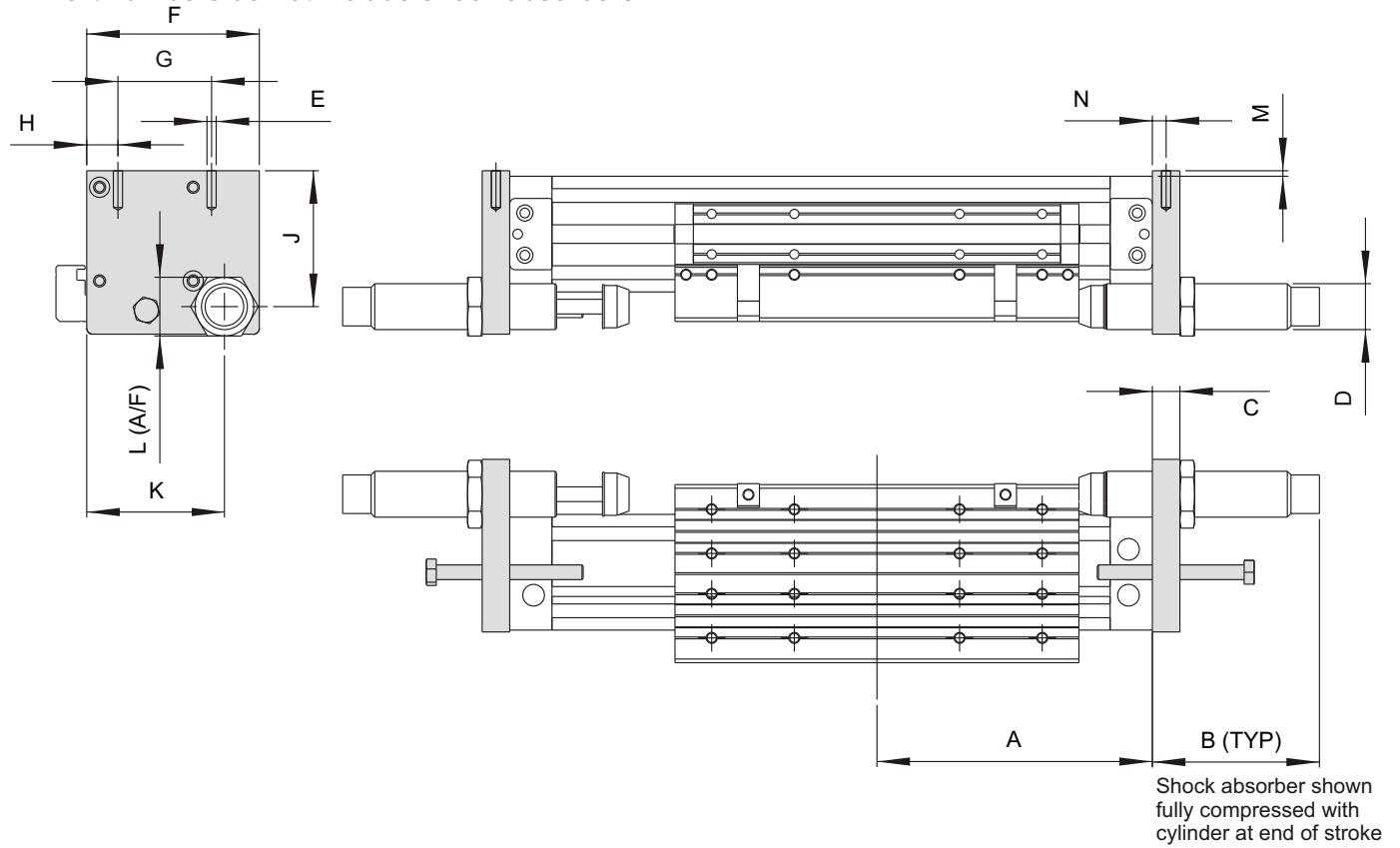

Mounting part number	Cylinder Ø (mm)	A (Standard)	A (Compact)	B	C	D	E	F	G
KCRM018K03	18	80	57.5	62.0	8	M14x1.5	M3x10	44.5	23.5
KCRM025K03	25	100	67.5	56.0	10	M14x1.5	M4x10	58.0	33.0
KCRM032K03	32	120	77.5	56.0	12	M14x1.5	M5x12	71.0	41.0
KCRM040K03	40	150	95.0	91.0	15	M25x1.5	M6x15	94.0	51.0
KCRM050K03	50	180	105	91.0	15	M25x1.5	M8x20	103.0	63.0
KCRM063K03	63	215	125	82.5	15	M25x1.5	M8x20	119.5	78.0

Mounting part number	Cylinder Ø (mm)	H	J	K	L	M	Suggested Shock Absorber
KCRM018K03	18	9.0	37.0	36.5	17	2.0	KAD1410
KCRM025K03	25	13.5	50.0	50.0	17	2.0	KAD1410
KCRM032K03	32	15.5	61.5	61.0	17	2.0	KAD1410
KCRM040K03	40	17.0	74.0	75.0	32	3.0	KAD2525
KCRM050K03	50	23.5	90.0	89.0	32	3.0	KAD2525
KCRM063K03	63	21.0	107	105.5	32	4.5	KAD2525

#### Shock Absorbers

See page 1.17

#### Ordering Information: By part number



® Issue 1 Oct 02

## Dimensions and performance data

units mm

### Mountings – T Slot Mounting Nut

#### Features

- ◆ Fixing nut carefully engineered to cope with substantial stresses
- ◆ Provides secure M5 mounting point
- ◆ Allows fitting of accessories directly to the cylinder body

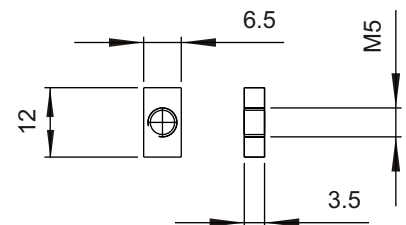
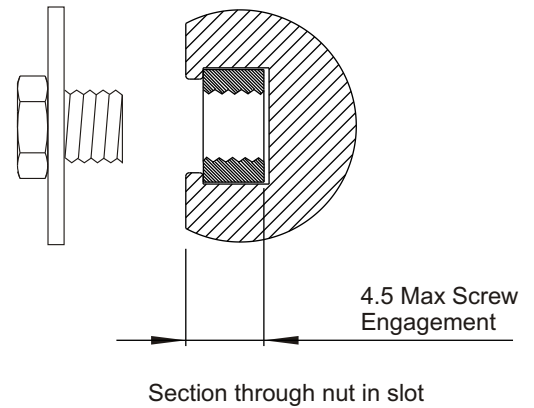
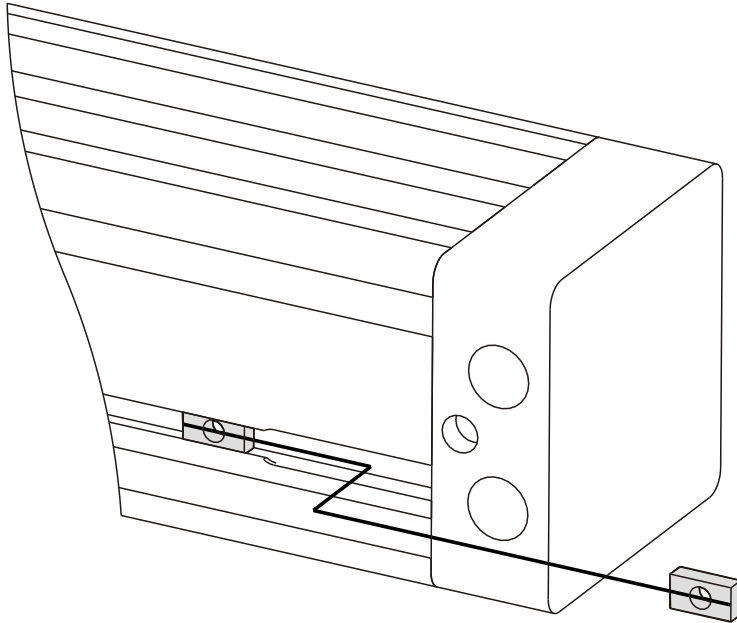

Mounting part number	Cylinder Ø (mm)
KTNM5	25 - 63

Ordering Information:  
By part number



® Issue 1 Oct 02